

Simply clean water.



Mature technical solutions for the treatment of wastewater from residential areas, villages, hotels and commercial applications

AQUAmax[®]

CONTENTS

• ATB firm's history	Page 3	• Sausage and cold meat factory, Germany	Page 19
• ATB branches and partners worldwide	Page 4	• Camping sit, Belgium	Page 20
• AQUAmax® PROFESSIONAL plant engineering	Page 6	• Winter sport facility, Lithuania.....	Page 21
• AQUAmax® PROFESSIONAL functional procedures	Page 8	• Chwalimki village, Poland	Page 22
• Synoptical table.....	Page 9	• Coal mine, Mozambique.....	Page 23
• Project references.....	Page 10	• Company building, Vietnam.....	Page 24
• Gas-fired power plant, Trinidad and Tobago.....	Page 11	• University, India	Page 25
• Cheese dairy, France	Page 12	• Coffee finca, Mexico	Page 26
• Nuclear power station, Belgium	Page 13	• Caravan/holiday house park, Great Britain	Page 27
• Old people's home, Mexico	Page 14	• Camarasu village, Romania	Page 28
• Home for the handicapped, France.....	Page 15	• Durău village, Romania.....	Page 29
• Hotel/restaurant, France	Page 16	• Lacusteni village, Romania	Page 30
• Self-catering house, Germany.....	Page 17	• Police headquarters, Jordan	Page 31
• Tourist centre, Croatia	Page 18		





Construction of the first prototypes in the cellar of the Baumann family house



ATB laboratory



ATB company base in Porta Westfalica (Germany)

Nothing can replace experience...

Who are we and what do we do?

The ATB Umwelttechnologien GmbH, based in Porta Westfalica, was founded in 1999 by the Baumann family. We are concerned almost exclusively with the development/production and the marketing of biological small wastewater treatment plants and small-scale wastewater treatment plants as well as associated peripheries (spare parts shop, maintenance, laboratory service). Since the beginning of 2014 we are, in addition, manufacturing plastic components for wastewater treatment plants/wastewater engineering in the rotation process. At our site in Weißensee/Thüringen we are producing modern multi-chamber tanks made from precast concrete components (with this we are in a position to supply complete wastewater plants) and collecting pits for stormwater/wastewater.

In our standard product portfolio are numbered the small wastewater treatment plants PUROO®, AQUAmax® BASIC/CLASSIC, APURIS® and McWater® as well as wastewater treatment plants of the AQUAmax® PROFESSIONAL series.

The AQUAmax® series

At that time everything started with the idea of designing small wastewater treatment plants for installation partners and operators which were to be as simple as possible. After many long nights and weeks full of research, conceptual designs, the first equipment tests in the garden pond and renewed modifications the AQUAmax® small wastewater treatment plant was finally ready. For the time being, configured for private households only, the concept was developed steadily further and today covers many professional applications from the commercial field (hotel/catering/foodstuffs processing) as well as wastewater treatment for residential areas and municipalities.

On the following pages we would like to give you a small overview of the employment possibilities of our AQUAmax® PROFESSIONAL wastewater treatment plants.

Enjoy the reading!

AVAILABLE TO YOU WORLDWIDE

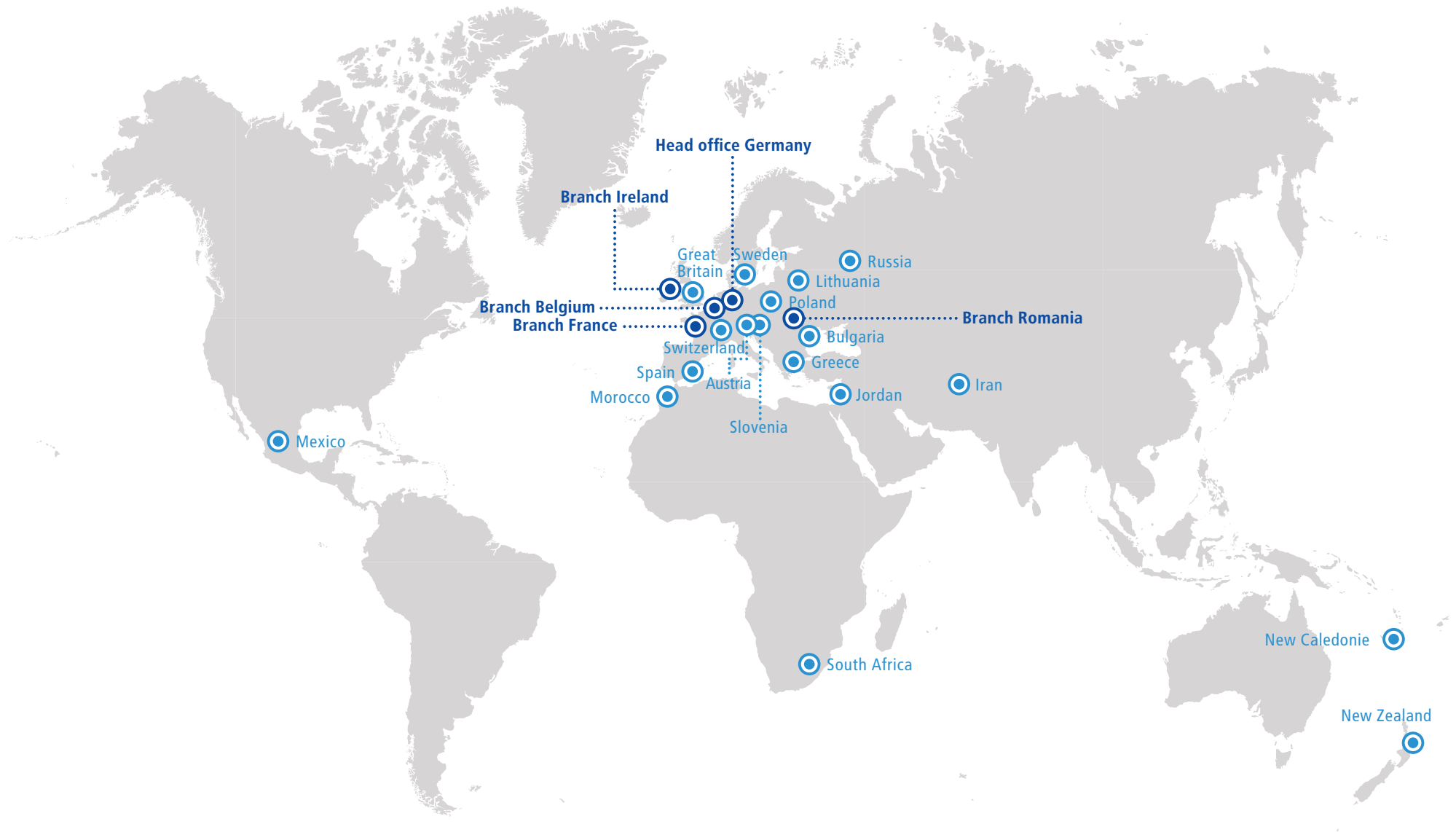

ATB BRANCHES AND DISTRIBUTION PARTNERS



Austria | Distribution partner in Klagenfurt

Belgium | Branch in Spa

Bulgaria | Distribution partner in Varna

France | Branch in Ballots

Germany | Head office in Porta Westfalica, concrete works in Weißensee, distribution partners across the whole of Germany

Great Britain | Distribution partner in Beeston

Greece | Distribution partner in Salonika

Iran | Distribution partner in Teheran

Ireland | Branch in Celbridge

Jordan | Distribution partner in Amman

Lithuania | Distribution partner in Kaunas

Mexico | Distribution partner in Tlaxcala

Morocco | Distribution partner in Agdal Rabat

New Caledonia | Distribution partner in Nouméa

New Zealand | Distribution partner in Warkworth

Poland | Distribution partner in Swarzedz

Romania | Branch in Sibiu

Russia | Distribution partner in Moscow

Slovenia | Distribution partner in Sentilj and Zalec

South Africa | Distribution partner in Bryanston

Spain | Distribution partner in Moraira

Sweden | Distribution partner in Vollsjö

Switzerland | Distribution partner in Luzern

Naturally, in this sector, there are always a few changes.

The current listing of our branches and partners as well as complete contact data can be found on our website www.atbnet.eu

SYSTEMS ENGINEERING



AQUAmax® PROFESSIONAL GZ 1-16
For 1-16 PT



AQUAmax® PROFESSIONAL GZ 17-50
For 17-50 PT



AQUAmax® PROFESSIONAL XL
For 60-600 PT



AQUAmax® PROFESSIONAL XLA/XLAM/XXL
For 300-5,000 PT

Real professionals go for the AQUAmax® PROFESSIONAL series

- **Universally deployable**
The AQUAmax® PROFESSIONAL series is suitable for almost every biologically degradable wastewater.
- **Flexible – also with retrofitting**
Independent of material and geometry the plants can be installed in very nearly all types of tank – from concrete via plastic up to GRP tanks.
- **First-class discharge values**
AQUAmax® PROFESSIONAL plants are dimensioned according to the project-specific data. The configuration is effected depending on required treatment performance.
- **Disinfection**
Optional: secure disinfection through UV after-treatment or chlorination.
- **Phosphate precipitation**
The proControl® control system is prepared for the activation of an external phosphate precipitation.
- **Future-assured**
Through the AQUAmax® modular construction system your plant is at all times expandable, through software updates at all times adaptable to the best available technology.
- **Experience, security & service**
The top-selling SBR wastewater treatment plant in Germany, installed thousands of times worldwide!

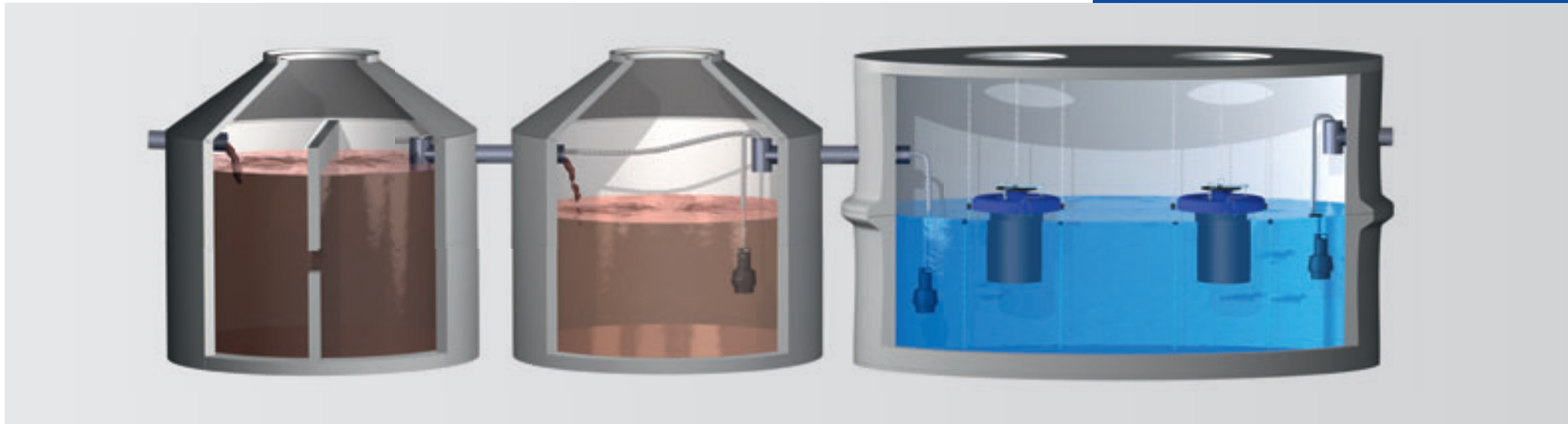

Solutions for almost every situation and requirement

In collaboration with test institutes and universities at home and abroad, the AQUAmax® PROFESSIONAL wastewater treatment system has been developed on the basis of our market-leading small wastewater treatment plants AQUAmax® BASIC & CLASSIC, especially for users from the commercial sector as well as for smaller communities.

It functions on the established and proven SBR process, which is employed successfully in full scale engineering and also with small wastewater treatment plants. On this basis the AQUAmax® PROFESSIONAL system enables high quality, extremely economic solutions for almost every professional requirement.

The AQUAmax® PROFESSIONAL series was conceived specially for highly loaded wastewater from hotel, catering, commercial and food processing operations as well as for residential areas and smaller villages.

Our standardised AQUAmax® PROFESSIONAL systems engineering covers the following areas:

- G-plants Applications up to 50 PT
- XL-plants Applications up to 600 PT
- XLA-/XLAM-plants Applications up to 1,000 PT

Furthermore, we offer our XXL plants for larger applications up to maximum 5,000 PT; these are planned project-specific.

FUNCTIONAL PROCEDURES

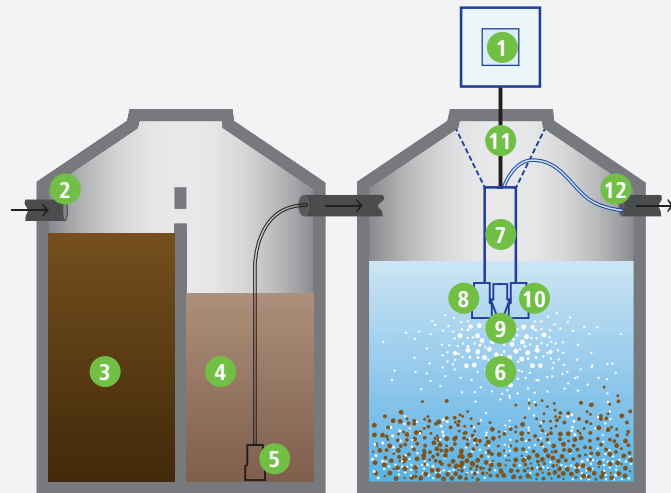

AQUamax[®] PROFESSIONAL G

1. Automatic control
2. Inlet
3. Primary treatment
4. Buffer
5. Feeding pump
6. SBR tank
7. Carrier frame
8. Submersible motor pump (clarified water)
9. Submersible motor aerator
10. Submersible motor pump (sludge return)
11. Control cable
12. Outlet

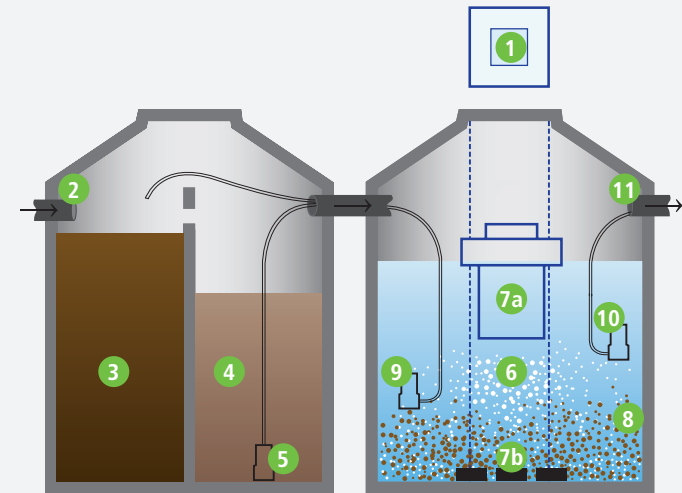

AQUamax[®] PROFESSIONAL XL, XLA, XLAM

1. Automatic control
2. Inlet
3. Primary treatment
4. Buffer
5. Feeding pump
6. SBR tank
7. Aeration system (Variant a: with surface aerator or Variant b: with strip aerator and compressor)
8. Submersible motor agitator (with XLAM plants only; not shown here)
9. Submersible motor pump (sludge return)
10. Submersible motor pump (clarified water)
11. Outlet

Our standardised AQUAmax® PROFESSIONAL plant series

G	XL1	XL2	XLA	XLAM
GZ 1-16 <ul style="list-style-type: none"> • Connection value: 1-16 PT • With submersible motor aerator • Chain suspension system 	XL1-A0.75 <ul style="list-style-type: none"> • Connection value: 60-100 PT • With surface aerator 	XL2-A1.5 <ul style="list-style-type: none"> • Connection value: 60-300 PT • With surface aerator 	XLA-3.0 <ul style="list-style-type: none"> • Connection value: up to 500 PT • With surface aerator 	XLAM-5.5 <ul style="list-style-type: none"> • Connection value: up to 400 PT • With surface aerator & mixer
GZ 17-50 <ul style="list-style-type: none"> • Connection value: 17-50 PT • With submersible motor aerator • Chain suspension system 	XL1-A1.5 <ul style="list-style-type: none"> • Connection value: 90-300 PT • With surface aerator 	XL2-A3.0 <ul style="list-style-type: none"> • Connection value: 175-600 PT • With surface aerator 	XLA-4.0 <ul style="list-style-type: none"> • Connection value: 500-750 PT • With surface aerator 	XLAM-7.5 <ul style="list-style-type: none"> • Connection value: 400-500 PT • With surface aerator & mixer
G-B 17-50 <ul style="list-style-type: none"> • Connection value: 17-50 PT • With compressor 	XL1-B1.1/4.5 <ul style="list-style-type: none"> • Connection value: 60-70 PT • With compressor 	XL2-B2.2/9.0 <ul style="list-style-type: none"> • Connection value: 120-140 PT • With compressor 	XLA-5.5 <ul style="list-style-type: none"> • Connection value: 750-1,000 PT • With surface aerator 	XLAM-11.0 <ul style="list-style-type: none"> • Connection value: 500-750 PT • With surface aerator & mixer
	XL1-B1.85/6.0 <ul style="list-style-type: none"> • Connection value: 71-100 PT • With compressor 	XL2-B3.7/12.0 <ul style="list-style-type: none"> • Connection value: 141-200 PT • With compressor 		XLAM-15.0 <ul style="list-style-type: none"> • Connection value: 750-1,000 PT • With surface aerator & mixer
XXL				

XXL plants are planned project-specific up to a maximum of 5,000 PT.

Possible areas of application of the plant systems are hotel/catering/commercial operations, food processing companies, residential areas/villages/towns, public buildings/installations, tourism facilities.



The specific connection values are dependent on the required treatment target. Other plant types/sizes on request.
 A detailed catalogue "AQUAmax® PROFESSIONAL XL (50 - 1,000 PT)" can be found in the download area in www.atbnet.eu or please speak to our sales team.
 In addition to our standardized plants we naturally also offer individual solutions.

PROJECT REFERENCES



Our plants in operation

In order to be able to create a better understanding of the application possibilities of our wastewater treatment plant systems, we have decided, along with the technical explanations, to present you with a selection of our already realised projects – with different basic prerequisites, specifications and in various sizes.

Our AQUAmax® PROFESSIONAL series is standardised; this, however, does not eliminate individual adjustments to the respective conditions – quite the contrary!





The project at a glance

Category	Domestic wastewater
Location	Trinidad and Tobago
Installed plant	AQUAmax® PROFESSIONAL G
Connection value	40 PT
Wastewater quantity	6.0 m ³ /day
BOD₅ pollutant load	2.4 kg/day
Commissioning	2010

A wastewater treatment plant was installed on the site of a gas-fired power plant on Trinidad. Two pump stations convey the wastewater to be treated from various buildings to the wastewater treatment plant. A UV unit for disinfection was retrofitted in 2013.

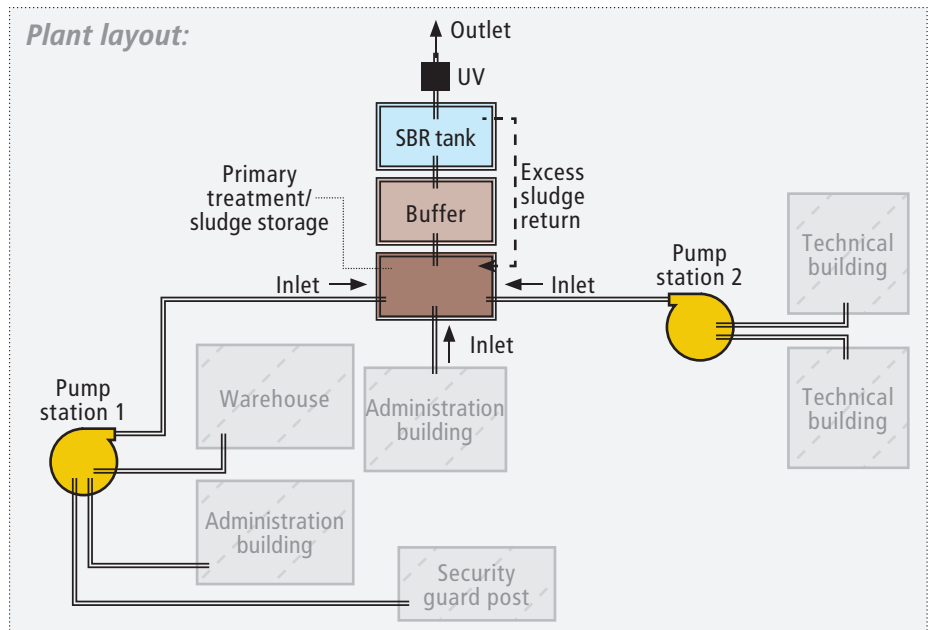

CHEESE DAIRY [60 PT]

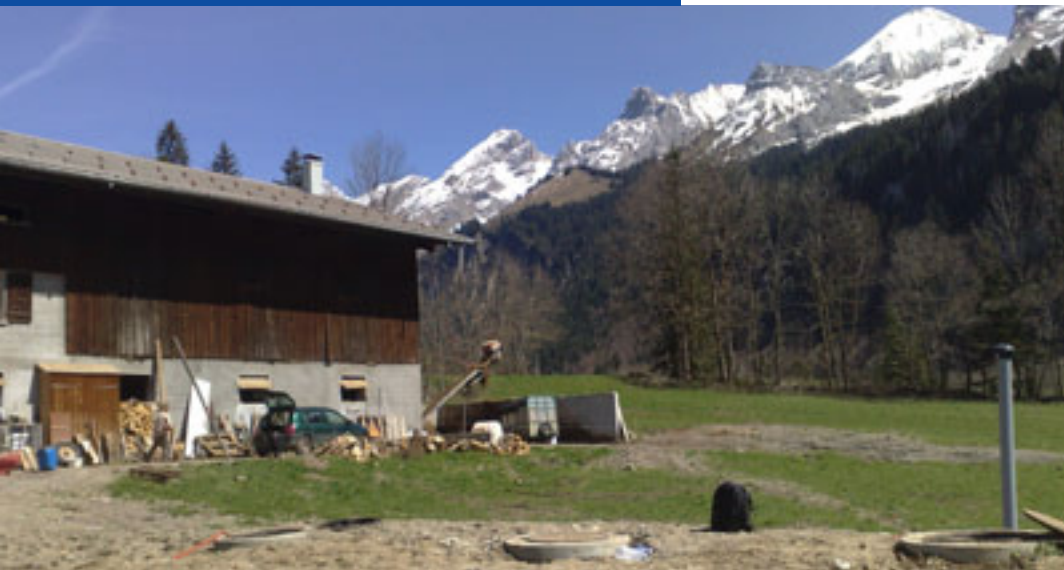

The project at a glance

Category	Food processing
Location	Le Grand-Bornand, France
Installed plant	AQUAmax® PROFESSIONAL XL1-100
Connection value	60 PT
Wastewater quantity	1.8 m ³ /day
BOD₅ pollutant load	3.6 kg/day
Commissioning	2010

The wastewater treatment plant with aerated primary treatment and separate sludge storage treats the production wastewater and the domestic wastewater of the employees of a cheese dairy located in the French Rhône-Alpes region. An already present cesspit is used as sludge storage.

Plant layout:

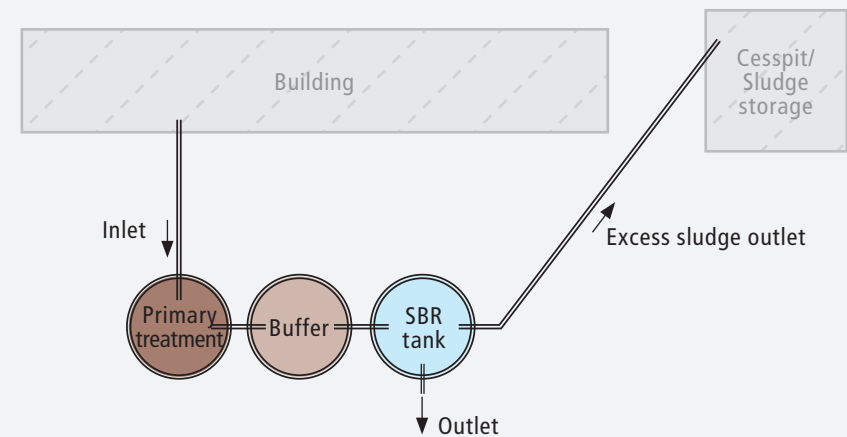



The project at a glance

Category	Domestic wastewater
Location	Huy, Belgium
Installed plant	AQUAmax® PROFESSIONAL XL1-100
Connection value	respectively 60-75 PT
Wastewater quantity	respectively 11.25 m ³ /day
BOD₅ pollutant load	respectively 4.5 kg/day
Commissioning	2011

A wastewater treatment plant was installed at each of two locations on the site of a nuclear power station in Huy on the River Maas.

Plant layout:

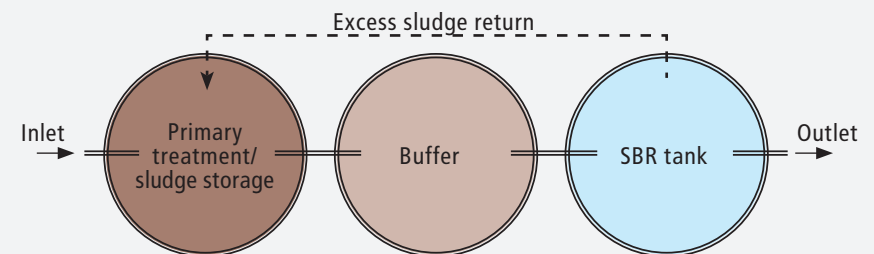

MEXICO OLD PEOPLE'S HOME [75 PT]



The project at a glance

Category	Domestic wastewater
Location	Mexico City, Mexico
Installed plant	AQUAmax® PROFESSIONAL XL1-100
Connection value	75 PT
Wastewater quantity	16.5 m ³ /day
BOD₅ pollutant load	4.5 kg/day
Commissioning	2010

The wastewater treatment plant treats the domestic wastewater of a complete care establishment (inhabitants, employees, kitchen, ...) and is connected with a subsequent irrigation unit. The outflowing treated wastewater is used for the irrigation of the on-site park with numerous plants.

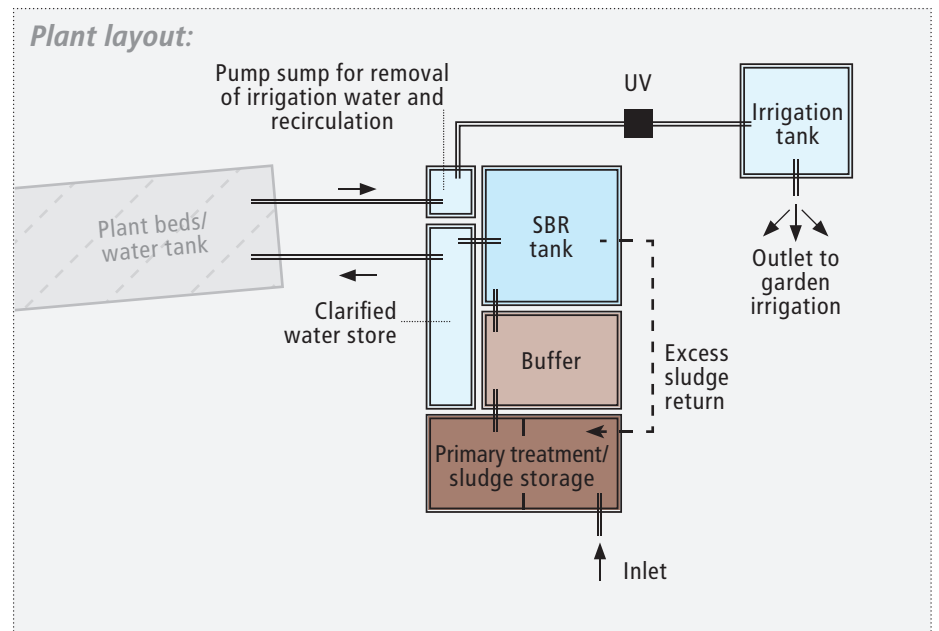



The project at a glance

Category	Domestic wastewater
Location	La Selle Craonnaise, France
Installed plant	AQUAmax® PROFESSIONAL XL1-100
Connection value	85 PT
Wastewater quantity	12.75 m ³ /day
BOD₅ pollutant load	5.1 kg/day
Commissioning	2011

The three tank plant treats the domestic wastewater of the complete establishment (inhabitants, employees, kitchen) in Northwest France.

Plant layout:

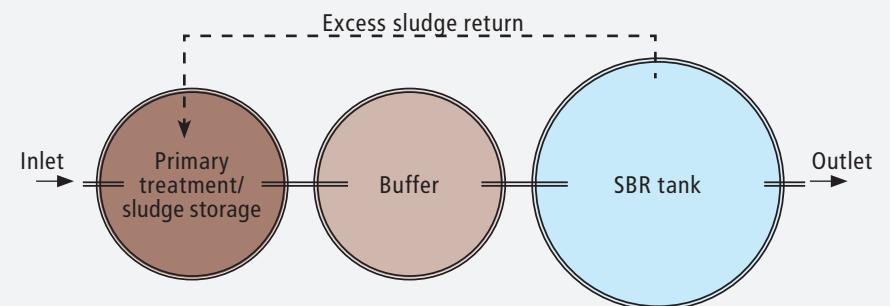

HOTEL/RESTAURANT [85 PT]



The project at a glance

Category	Gastronomy
Location	Cuers, France
Installed plant	AQUAmax® PROFESSIONAL XL1-100
Connection value	85 PT
Wastewater quantity	12.75 m ³ /day
BOD₅ pollutant load	5.1 kg/day
Commissioning	2011

The wastewater treatment plant treats the domestic wastewater of the guests and employees of a hotel/restaurant on the Côte d'Azur.

Plant layout:

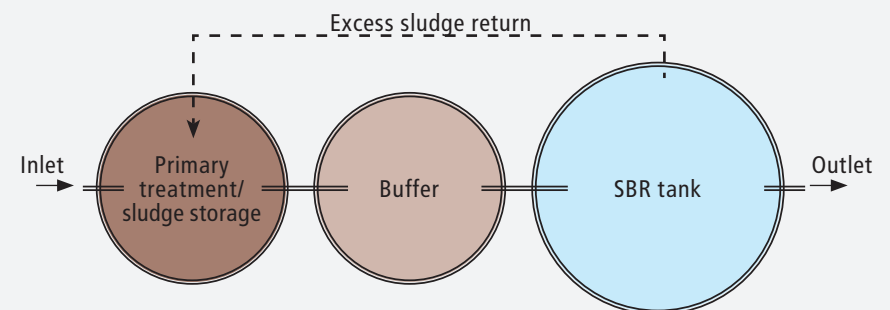



The project at a glance

Category	Tourism & Leisure
Location	Dinslaken, Germany
Installed plant	AQUAmax® PROFESSIONAL XL1-100
Connection value	95 PT
Wastewater quantity	12 m ³ /day
BOD₅ pollutant load	5.7 kg/day
Commissioning	2012

In the northwest of the Ruhr area, on the lower part of the Lower Rhine, there is a selfcatering house with associated camping site which accommodates up to 93 persons. The domestic wastewater of the guests and the wastewater produced from cleaning activities, after treatment run off directly into an already available irrigation system.

Plant layout:

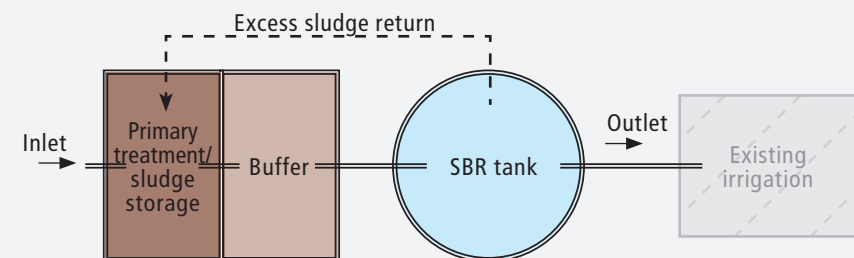

TOURIST CENTRE: HOTEL/RESTAURANT/TRAVEL AGENCY [125 PT]



The project at a glance

Category	Gastronomy & Tourism
Location	Slunj, Croatia
Installed plant	AQUAmax® PROFESSIONAL XL1-125
Connection value	125 PT
Wastewater quantity	20 m ³ /day
BOD₅ pollutant load	7.5 kg/day
Commissioning	2012

Three situations – one solution:

In the heart of Croatia there is a tourist centre whose hotel and travel agency with adjoining restaurant are one. Our wastewater treatment technology treats the domestic wastewater of the guests and staff as well as the wastewater of the hotel/restaurant operation.

Plant layout:

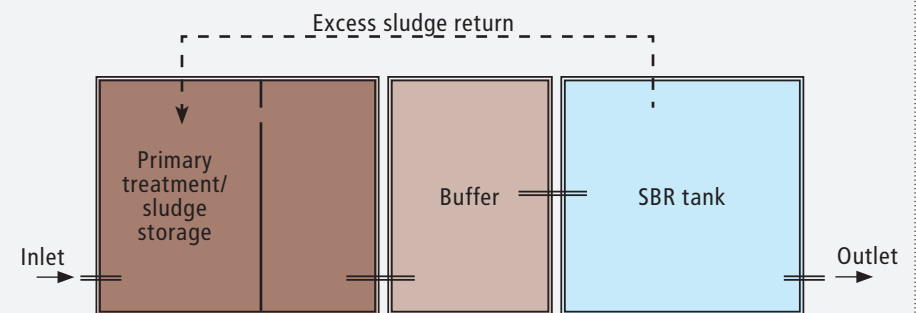



The project at a glance

Category	Food processing
Location	Westerwalsede, Germany
Installed plant	AQUAmax® PROFESSIONAL XL2-200
Connection value	200 PT
Wastewater quantity	10 m ³ /day
BOD₅ pollutant load	12 kg/day
Commissioning	2008

The two-line wastewater treatment plant treats the domestic wastewater of the employees and the production wastewater of a sausage and cold meat factory in the rural district of Rotenburg/Wümme.

Plant layout:

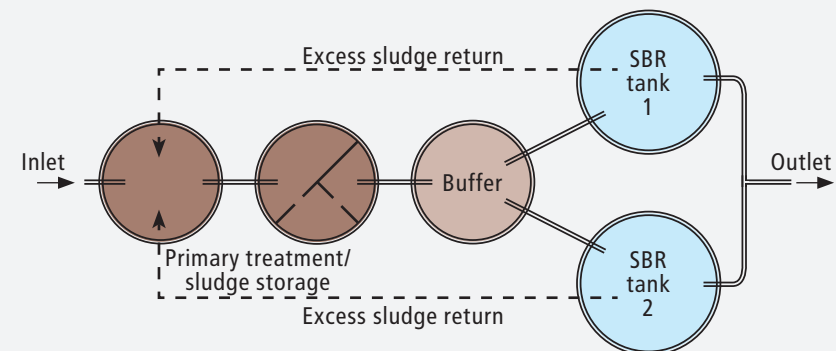

CAMPING SITE [200 PT]



The project at a glance

Category	Tourism & Leisure
Location	Büllingen, Belgium
Installed plant	AQUAmax® PROFESSIONAL XL2-200
Connection value	200 PT
Wastewater quantity	30 m ³ /day
BOD₅ pollutant load	12 kg/day
Commissioning	2012

In the Belgium town of Büllingen, near the German border, there is a camping site situated in a woods. The two-line wastewater treatment plant treats the complete wastewater of the site.

Plant layout:

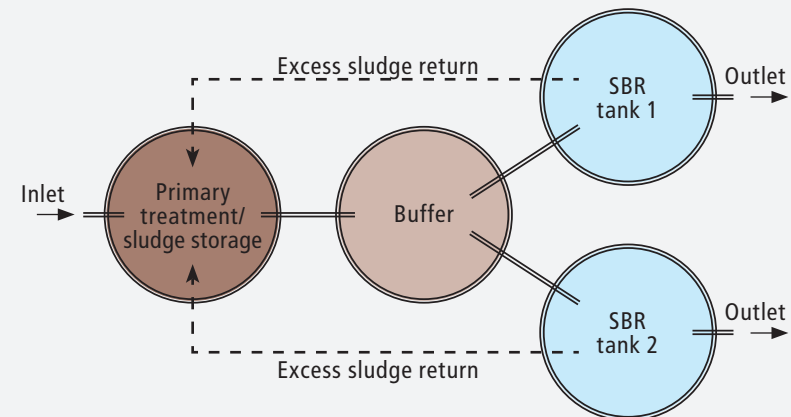



The project at a glance

Category	Tourism & Leisure
Location	Druskininkai, Lithuania
Installed plant	AQUAmax® PROFESSIONAL XL2-200
Connection value	200 PT
Wastewater quantity	35 m ³ /day
BOD₅ pollutant load	12 kg/day
Commissioning	2010

In South Lithuania, in a scenically attractive site amongst moraine hummocks in a forest landscape, is located a unique winter sport and entertainment complex. The wastewater treatment plant was designed for the following details: 370 seats in the restaurant, 100 seats in the convenience restaurant, maximum of 900 expected skiers/day and 50 employees.

Plant layout:

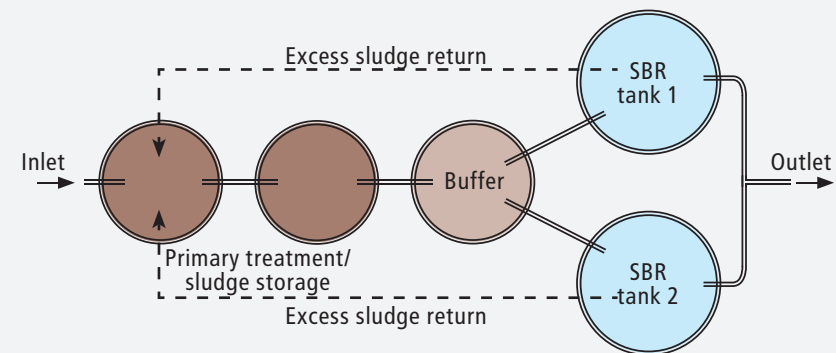

CHWALIMKI VILLAGE [225 PT]



The project at a glance

Category	Domestic/municipal wastewater
Location	Chwalimki, Poland
Installed plant	AQUAmax® PROFESSIONAL XL1-200
Connection value	225 PT
Wastewater quantity	27 m ³ /day
BOD₅ pollutant load	13,5 kg/day
Commissioning	2012

The installed wastewater treatment plant treats the municipal wastewater of the Polish village of Chwalimki in the Pomeranian lake region.

Plant layout:

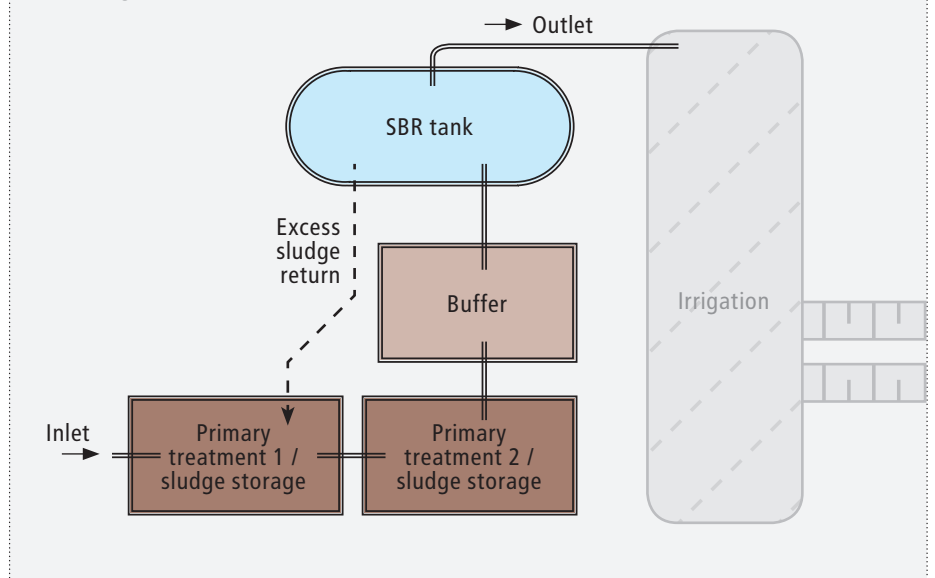

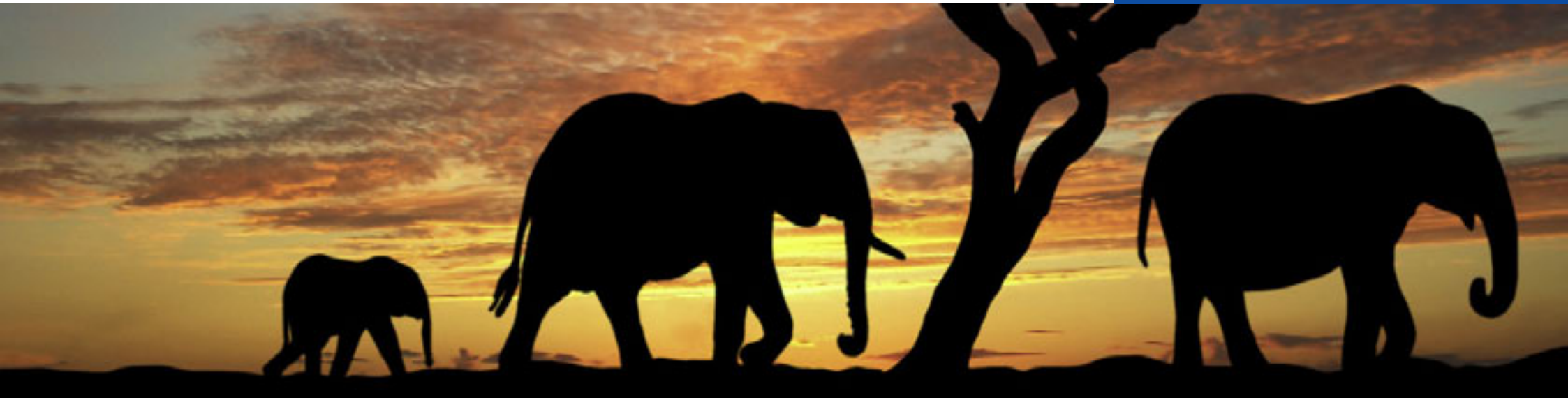

The project at a glance

Category	Domestic wastewater
Location	Nampula, Mozambique
Installed plant	AQUAmax® PROFESSIONAL XL2-500
Connection value	500 PT
Wastewater quantity	75 m ³ /day
BOD₅ pollutant load	30 kg/day
Commissioning	2010

Under Africa's sun...

The wastewater treatment plant is located in a coal mine and treats the domestic wastewater of the camp employees. The construction of the plant was supported with international aid money.

Plant layout:

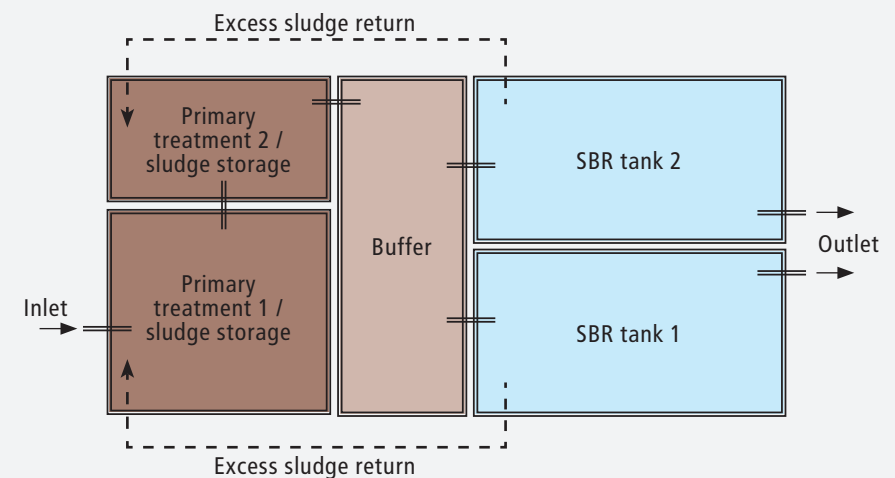

 COMPANY BUILDING/PREMISES [500 PT]



The project at a glance

Category	Domestic wastewater
Location	Hai Phong, Vietnam
Installed plant	AQUAmax® PROFESSIONAL XL2-500
Connection value	500 PT
Wastewater quantity	100 m ³ /day
BOD₅ pollutant load	25 kg/day
Commissioning	2007/2008

A wastewater treatment plant was required for a Vietnamese company located in the industrial area Hai Phong, in order to treat the domestic wastewater of the employees. In order also to be able to give an as high as possible flexibility in the future with regard to the location, a mobile container plant (a wastewater treatment plant made from several surface erected steel tanks) was employed.

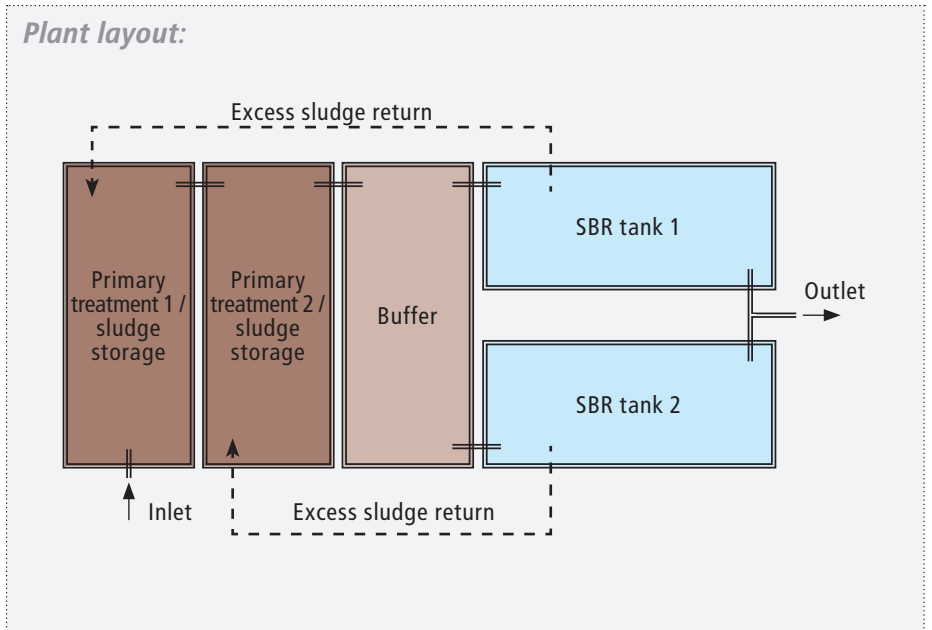



The project at a glance

Category	Domestic wastewater
Location	Chennai, India
Installed plant	AQUAmax® PROFESSIONAL XXL1-600
Connection value	600 PT
Wastewater quantity	90 m ³ /day
BOD₅ pollutant load	36 kg/day
Commissioning	2006

The plant with integrated UV disinfection daily treats up to 90 cubic metres of wastewater which, following treatment in an intermediate tank with a volume of ca. 60 cubic metres, is stored. The processed wastewater is used for the irrigation of green and garden areas of the university, thus the very long dry phases are also well bridged.

Plant layout:

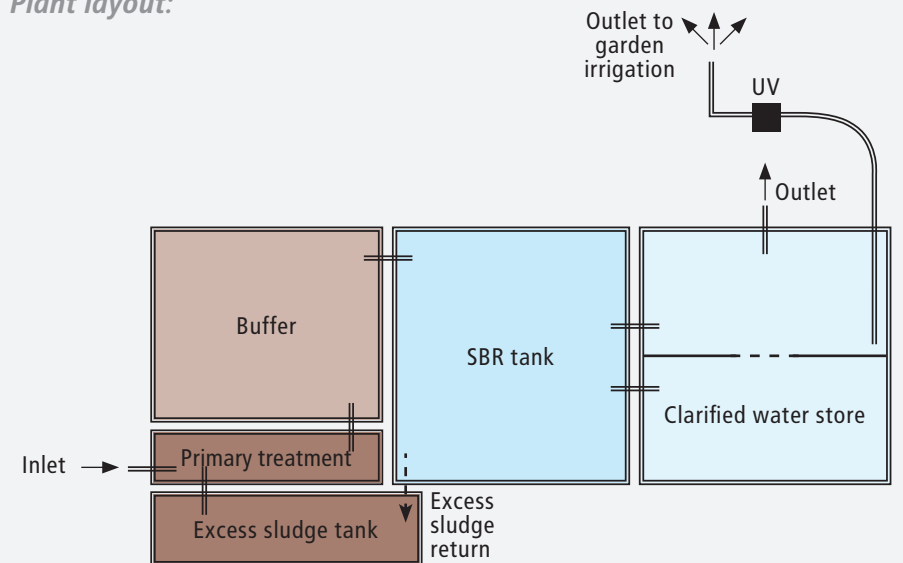

COFFEE FINCA [1,000 PT]



The project at a glance

Category	Food processing
Location	Tapachula, Mexico
Installed plant	AQUAmax® PROFESSIONAL XXL1-1.000
Connection value	1,000 PT
Wastewater quantity	145 m ³ /day
BOD₅ pollutant load	60 kg/day
Commissioning	2006

The smaller SBR aeration tank runs continuously throughout the year and is designed for the domestic wastewater of the regular staff (ca. 150 PT). During the harvest time both the domestic wastewater of the additionally employed personnel and also the production wastewater are clarified in a second tank. A pH neutralization is integrated in the wastewater treatment plant, a humification of the sludge on a plant bed tops off the process.

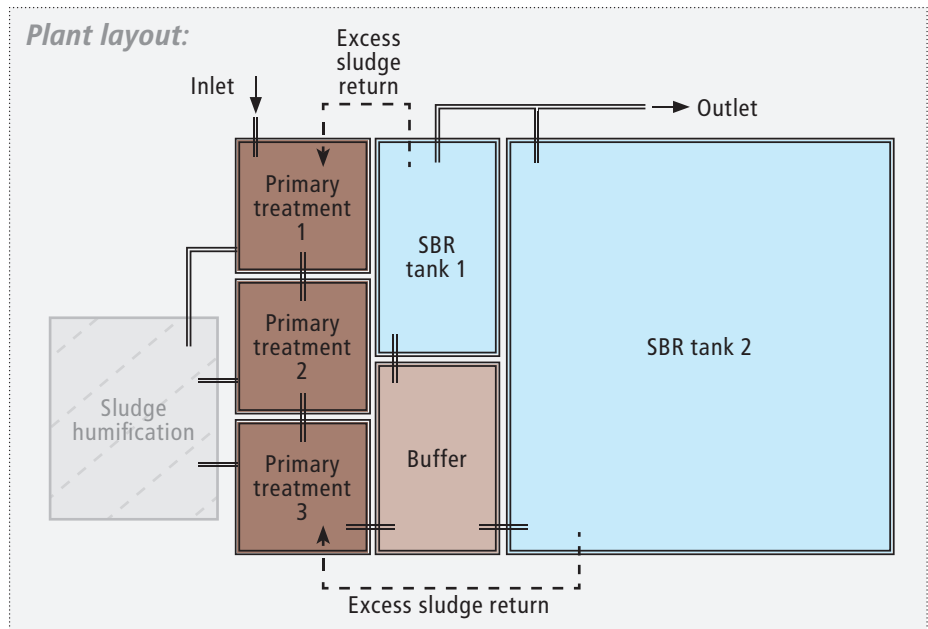



CARAVAN PARK [1,000 PT]



The project at a glance

Category	Tourism & Leisure
Location	Grassington Skipton, Great Britain
Installed plant	AQUAmax® PROFESSIONAL XXL1-1.000
Connection value	1,000 PT
Wastewater quantity	150 m ³ /day
BOD₅ pollutant load	60 kg/day
Commissioning	2005

The caravan park is located in North Yorkshire. The complete domestic wastewater of the park is treated by a SBR plant, which is designed for 1,000 PT. Due to the limited acceptance capacity of the local percolation field a plastic tank with throttled outlet was employed for the clarified water discharge.

Plant layout:

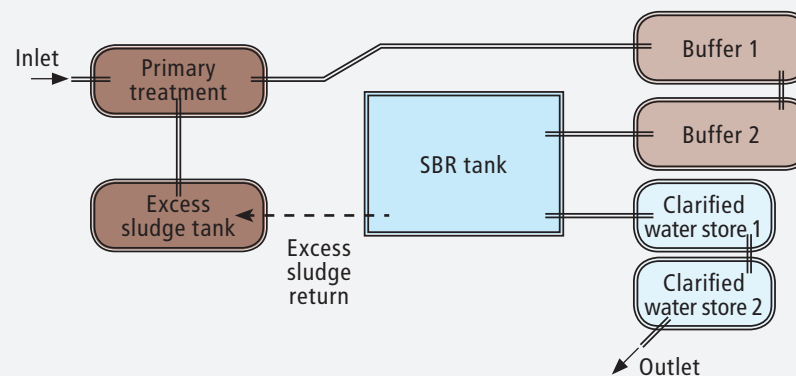

CAMARASU VILLAGE [1,000 PT]



The project at a glance

Category	Domestic/municipal wastewater
Location	Camarasu, Romania
Installed plant	AQUAmax® PROFESSIONAL XXL1-1.000
Connection value	1,000 PT
Wastewater quantity	150 m ³ /day
BOD₅ pollutant load	60 kg/day
Commissioning	2012

The wastewater treatment plant for the municipal wastewater of the village is designed for 1,000 PT. After running through the mechanical and biological treatment units the water is chlorinated and fed away to discharge. In addition, there is a sludge dewatering unit available for excess sludge.

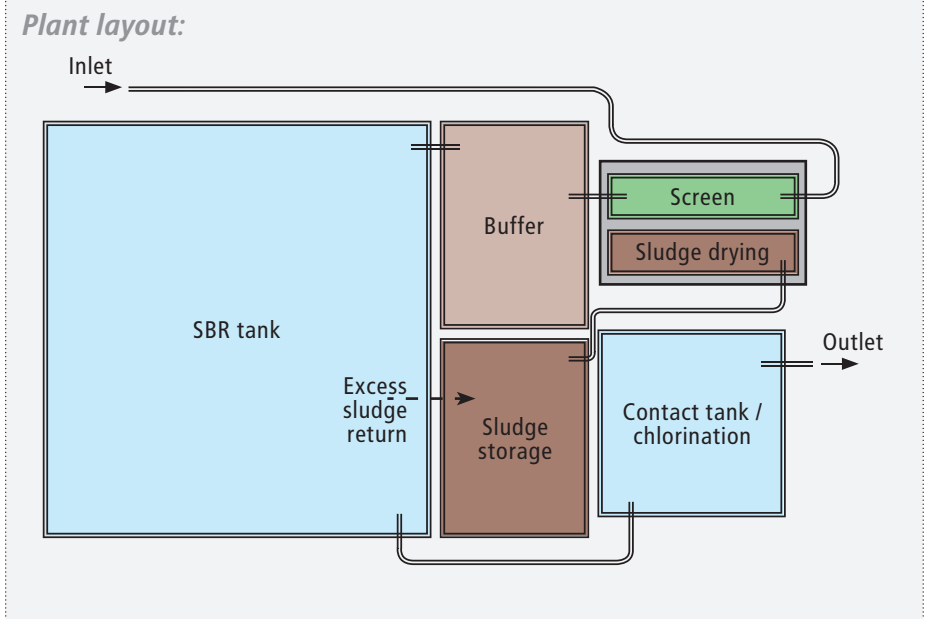



The project at a glance

Category	Domestic/municipal wastewater
Location	Durău, Romania
Installed plant	AQUAmax® PROFESSIONAL XXL2-1.250
Connection value	1,250 PT
Wastewater quantity	187,5 m ³ /day
BOD₅ pollutant load	75 kg/day
Commissioning	2008

The village of Durău, recreation resort and ski area, particularly at the winter time, attracts sports enthusiastic holidaymakers. The installed wastewater treatment plant has therefore to master, in addition to the regular wastewater yield, also the seasonal peak.

For the wastewater treatment plant, in part old existing concrete tanks were lined with plastic and then used. In addition a mechanical screen and a sludge bag drainage were available.

Plant layout:

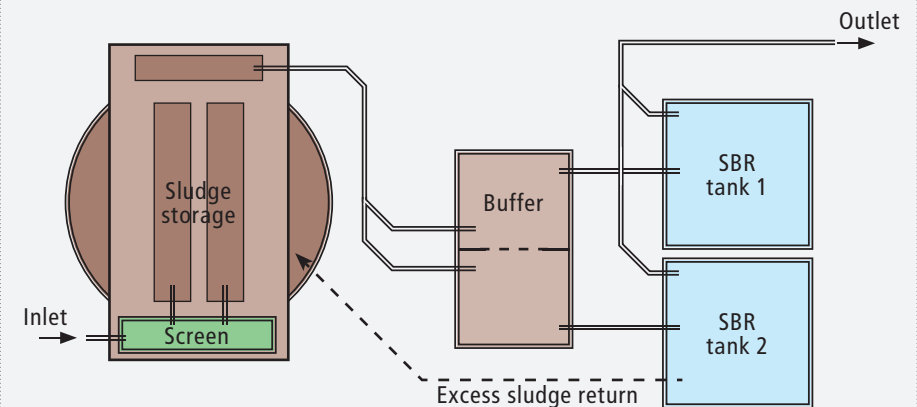

🇷🇴 LACUSTENI VILLAGE [1,500 PT]



The project at a glance

Category	Domestic/municipal wastewater
Location	Lacusteni, Romania
Installed plant	AQUAmax® PROFESSIONAL XXL1-1.500
Connection value	1,500 PT
Wastewater quantity	225 m ³ /day
BOD₅ pollutant load	90 kg/day
Commissioning	2011

The wastewater treatment plant for the village of Lacusteni, located in southwest Romania, is equipped with mechanical, biological and chemical treatment stages as well as with a UV unit and a sludge dewatering unit.

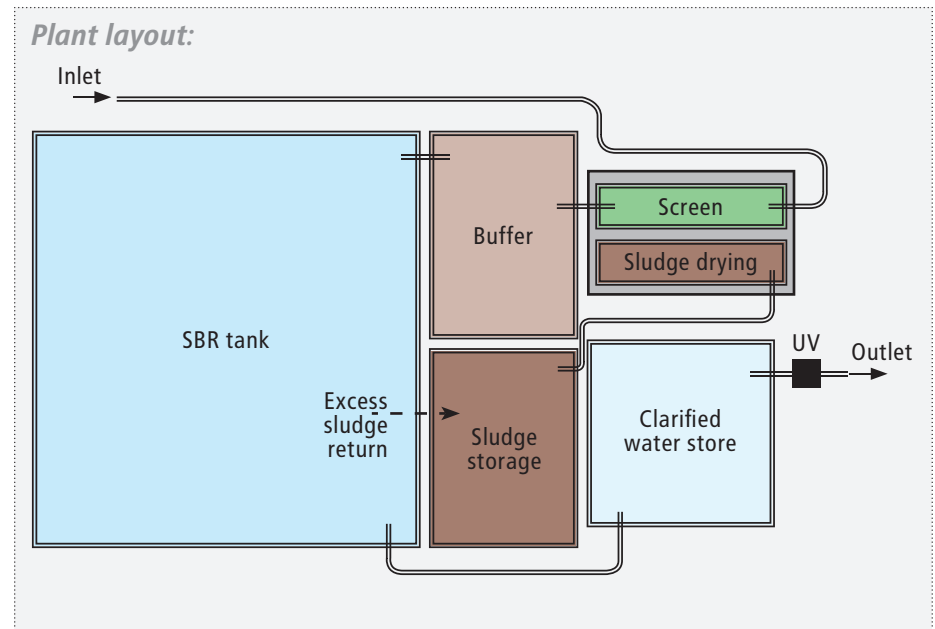



The project at a glance

Category	Domestic wastewater
Location	Amman, Jordan
Installed plant	AQUAmax® PROFESSIONAL XXL2AM-1870
Connection value	1,870 PT
Wastewater quantity	150 m ³ /day
BOD₅ pollutant load	112 kg/day
Commissioning	2013-2014

This two-line wastewater treatment plant is designed for 1,870 PT and was installed on the premises of a police headquarters. The wastewater is pre-treated by a grit chamber, then follows the primary treatment, a water storage facility, two SBR tanks and a sludge storage tank. In addition, a chlorination for disinfection has been integrated in order to be able to reuse the treated water for irrigation purposes.

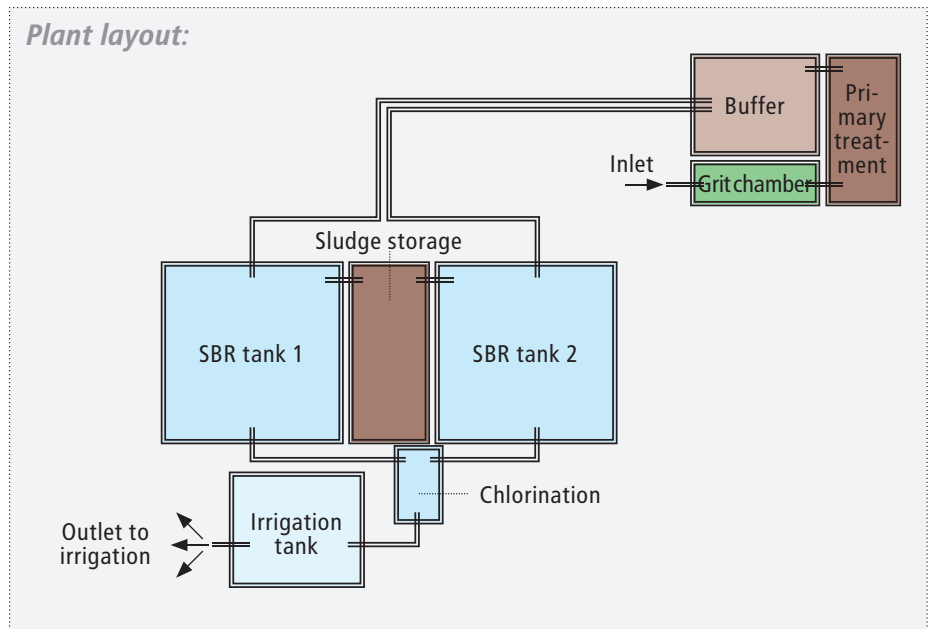

ATB – award winning...

Environment Prize 1999 of the German Federal State of Mecklenburg-Vorpommern • Environment Prize Austria 2001 • Founder Champion 2002 • OWL Innovation Prize 2003 • Financial Times Germany "Potential Innovation 2004"
"Finalist" Entrepreneur of the Year 2004, 2005 and 2006 • "Finalist" Grand Prize of Small and Medium-sized Businesses 2005 • Innovation Quality Seal "TOP 100" 2006 • "Winner" Grand Prize of Small and Medium-sized Businesses 2007
"Winner" GreenTec-Awards 2014, Category Water and Sewage



ATB Umwelttechnologien GmbH

Südstraße 2
32457 Porta Westfalica
Germany
Tel: +49 5731 30230-0
Fax: +49 5731 30230-30
E-Mail: info@atbnet.eu
Website: www.atbnet.eu

 [www.facebook.com/
ATB.Environmental](https://www.facebook.com/ATB.Environmental)